



RKJXT1F42001

Alps Electric

[Buy Now](#)



Looking for a discount?

[Check out our current promotions!](#)

Give us a call

1-855-837-4225

International: 1-415-281-3866

Email Us

Sales and New Orders: sales@verical.com

Order Support: support@verical.com

Suppliers: [Visit our seller page](#)

Company Address

Arrow Electronics, Inc
9201 East Dry Creek Road
Centennial, CO 80112

RKJXT1F 4-directional Stick Switch (with Encoder / Center-push Function)

A space-saving device with single shaft 4-directions/ push/encoder

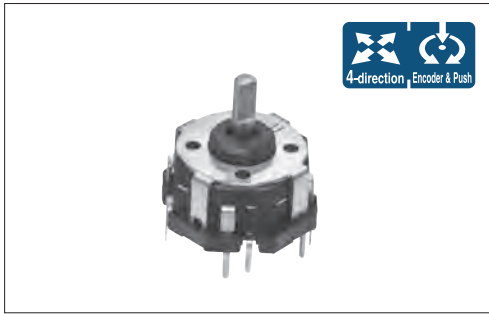

Typical Specifications (Stick Switches)

Items		Specifications
Ratings (max.) (Resistive load)		10mA 5V DC
Contact resistance	4-direction Center-push	1 Ω max.
Operating angle (4-direction)		Each direction 9° max.
Travel (Center push)		0.3±0.2mm
Operating life	Total with 4-direction	50,000 cycles
	Center-push	50,000 cycles

Typical Specifications (Encoders)

Items		Specifications
Ratings (max.) (Resistive load)		10mA 5V DC
Operating life		15,000 cycles

Product Line

Product No.	Stick Switches			Encoder			Minimum order unit (pcs.)	
	Maximum resolution	Operating force		Detent torque	Number of detent	Number of pulse	Japan	Export
	Direction	Center-push						
RKJXT1F42001	4	40±25mN·m	5±2N	15±8mN·m	30	15	1,320	2,640

Packing Specifications Tray

Number of packages (pcs.)		Export package measurements (mm)
1 case / Japan	1 case / export packing	
1,320	2,640	555×375×333

Dimensions

Unit:mm

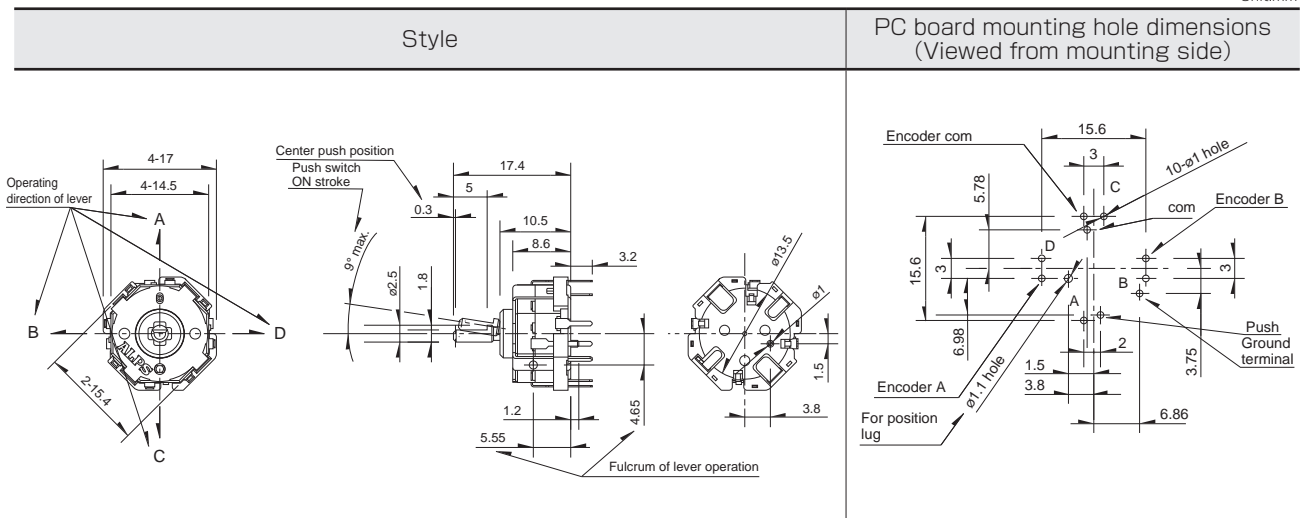

■ Output Relation Chart Between Lever Position and ON Position.

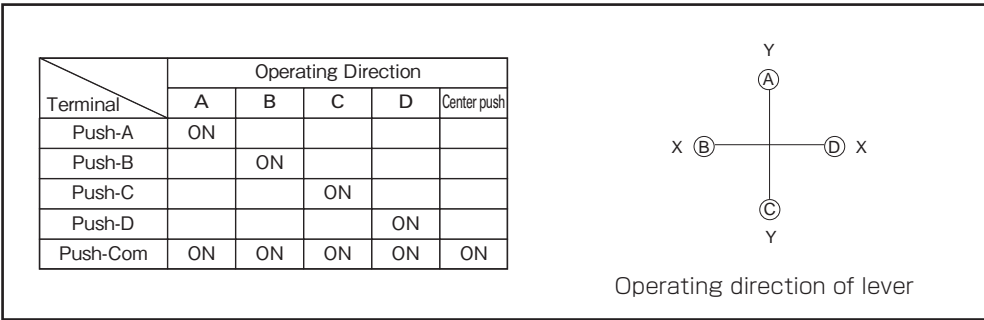

■ Circuit Diagram

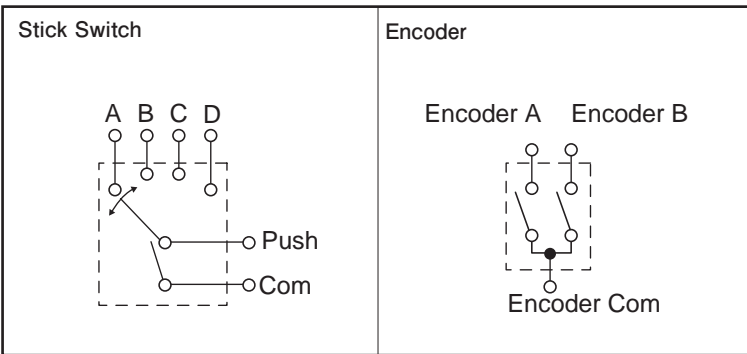



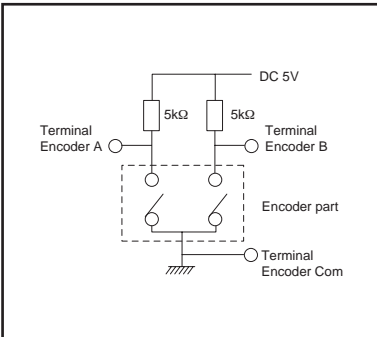



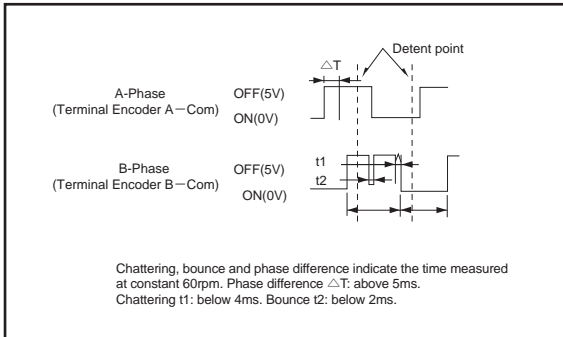

■ Test Circuit (Encoder)



■ Output Signal (Encoder)



Multi Control Devices
Variable Resistor Type
Switch Type

Type		Switch type			
Series		RKJXT1F	RKJXM	RKJXW	RKJXL
Photo					
Dimensions (mm)	W	17	11	36	13
	D			48.5	
	H	10.5	6.6	26.5	6.4
Shaft material		Metal			
Directional resolution		4-direction	8-direction		
Directional operating feeling (tactile feeling)		With			Without
Lever return mechanism		With			
Center-push switch		With			
Encoder		With	Without	With	Without
Operating temperature range		-40°C to +85°C			-30°C to +70°C
Operating life	Directional operation	Total with 4-direction 50,000 cycles	Total with 8-direction 100,000 cycles	30,000 cycles for each direction	8 directions total: 100,000 cycles
	Center-push			30,000 cycles	100,000 cycles
	Encoder	15,000 cycles	—	30,000 cycles	—
Automotive use		●	●	●	●
Life cycle (availability)					
Rating (max.) (Resistive load)		10mA 5V DC			
Electrical performance	Output voltage	—	—	—	—
	Encoder resolution	15pulses/360°	—	15pulses/360°	—
	Insulation resistance	100MQ min. 250V DC			
	Voltage proof	250V AC for 1min.		360V AC for 2s	300V AC for 1min. or 360V AC for 2s
Mechanical performance	Directional operating force	40±25mN·m	Direction A, B, C, D 30±20mN·m	2.5±1.5N	10±7mN·m
			Direction AB, BC, CD, DA 25±20mN·m		
	Push operating force	5±2N	3±1.5N		4.5±1N
	Encoder detent torque	15±8mN·m	—	30±20mN·m	—
	Terminal strength	5N for 1min.			
Actuator strength	Push / pull directions	100N (Push/Pull)	100N (Push), 50N (Pull)	100N (Push)	100N (Push), 50N (Pull)
	Operating direction	0.4N·m	0.3N·m	50N	100N
Environmental performance	Cold	-40°C 500h			
	Dry heat	85°C 500h			
	Damp heat	60°C, 90 to 95%RH 500h			
Page		398	400	402	404

Switch Type Multi Control Devices Soldering Conditions 412
Switch Type Multi Control Devices Cautions 413

Note

● Indicates applicability to all products in the series.

Switch Type Multi Control Devices / Soldering Conditions

Reference for Manual Soldering

Series	Tip temperature	Soldering time	No. of solders
RKJXT1F, RKJXM, RKJXL, SLLB, SLLB5, SRBE, SKRH	350±5°C	3s max.	1 time

Reference for Dip Soldering

Series	Preheating		Dip soldering		No. of solders
	Soldering surface temperature	Heating time	Soldering temperature	Soldering time	
RKJXT1F, RKJXM	100°C max.	2 min. max.	260±5°C	5±1s	2 time max.
RKJXL	120°C max.	70s max.	260°C max.	6s max.	2 time max.

Example of Reflow Soldering Condition

1. Heating method: Double heating method with infrared heater.
2. Temperature measurement: Thermocouple ϕ 0.1 to 0.2 CA (K) or CC (T) at soldering portion (copper foil surface).
A heat resisting tape should be used for fixed measurement.
3. Temperature profile

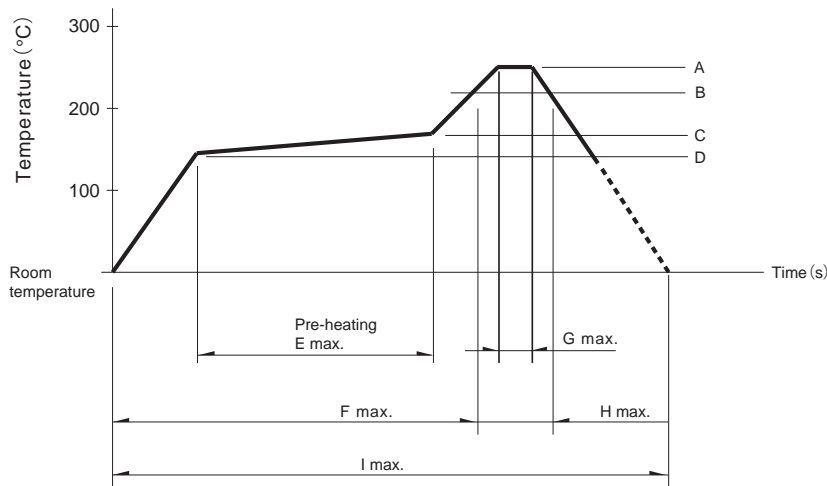

Series	A	B	C	D	E	F	G	H	I	No. of reflows
SLLB5	250°C	230°C	150°C	150°C	—	2 min.	—	30s	—	1 time
SLLB, SRBE	260°C	230°C	180°C	150°C	2 min.	—	—	40s	—	1 time
SKRH	260°C	230°C	180°C	150°C	2 min.	—	3s	40s	3-4 min.	2 times

Notes

1. The above temperature shall be measured on the mounting surface of a PC board. There are cases where the PC board's temperature greatly differs from that of the switch, depending on the material, size thickness of PC boards and others. The above-stated conditions shall also apply to switch surface temperatures.
2. Soldering conditions differ depending on reflow soldering machines. Prior verification of soldering condition is highly recommended.